

# PPTC Thermistor Introduction



## ■ What is the PPTC devices

The Polymeric Positive Temperature Coefficient (PPTC) device is a non-linear thermistor that limits current in electrical circuits, showing the non-linear PTC effect, but made from a composite of polymer and conductive particles, rather than ceramics. At normal working conditions, the device has much less resistance as compared to the remainder of the circuit, and has little or no influence on the performance of the circuit. Under a fault condition, the resistance of the PPTC device goes into a high resistance state, being called “tripping” the device. After the fault condition being eliminated, the PPTC device allows the circuit to return to the normal operating condition.

## ■ How does a PPTC device work

At normal working conditions, such as rated current and ambient temperature, the conductive particles form low-resistance networks in the polymer (as showed in figure 1). However, as a fault event occurs, such as over-current through the device or an increase in the ambient temperature causing the device's temperature over its switching temperature, the crystallite in the polymer melt and become amorphous. The increase in volume during melting of the crystalline phase causes the conductive particles being separated by the polymer, and reduces the conductive path networks, resulting in a large non-linear increase in the resistance of the device (as showed in figure 2).

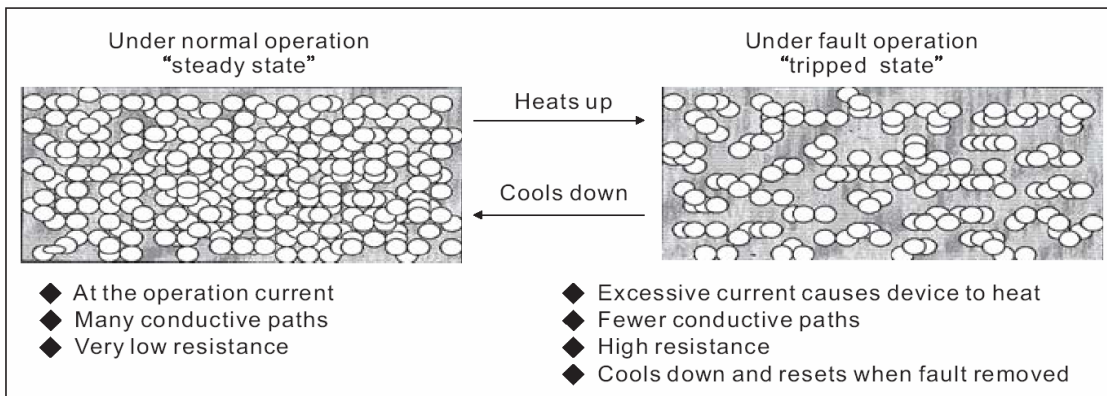

figure 1

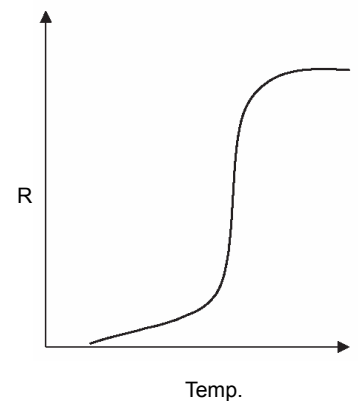
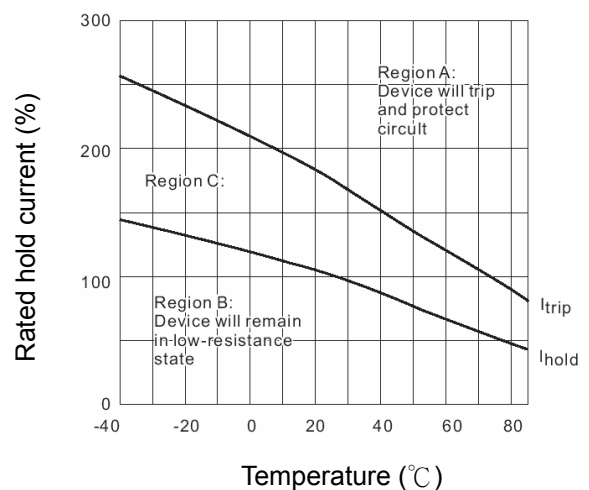

figure 2

## ■ Thermal derating

- Since the PPTC device is thermally activated, any fluctuation in ambient temperature will impact the performance of the device.
- As the ambient temperature increases, less energy ( $E=I^2R$ ) is required to “trip” the device (as showed in figure 3). In region C, the device will move to the region A or region B, depending on the device's resistance and the ambient conditions.

figure 3



# PPTC Thermistor Introduction



## ■ Trip time

- Thermal energy required to “trip” the device comes both from the transformation of the electrical energy through and the ambient temperature raising around.
- The larger over-current, power surge, or ambient temperature, the less trip time (as showed in figure 4).

figure 4

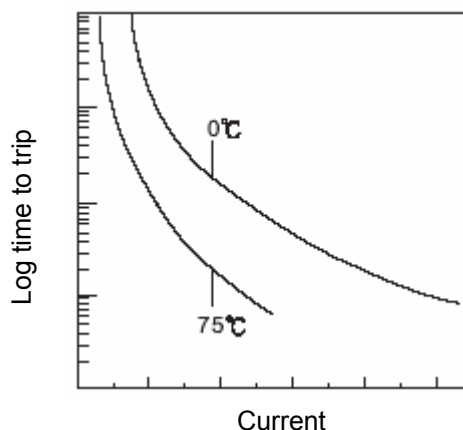

## ■ Reset

- The device resistance after “tripping” being recovered ( $R_{1max}$ ) is larger than the initial resistance. This is called the trip jump (as showed in figure 5).

figure 5

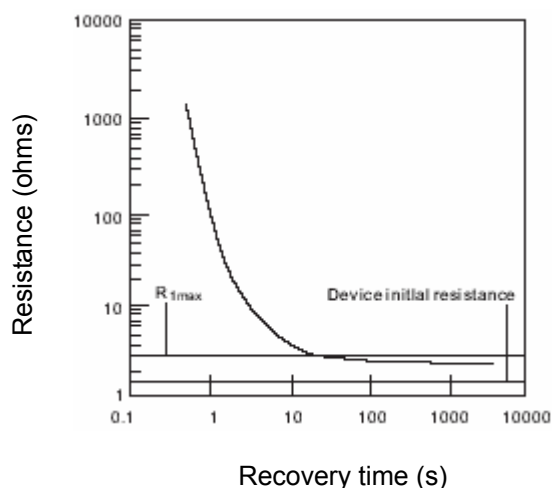

## ■ Related components comparison

Item	PPTC	CPTC	Bi-metal	Fuse
Resettable	Yes	Yes	Yes	No
Size	Small	Medium	Large	Large
Warranty cost	Low	Low	High	High
Power loss	Low	High	Low	Low
Resistance	Low	High	Low	Low
Response	Slow	Slow	Fast	Very fast/fast

## ■ Hold current ( $I_{hold}$ )

Maximum current device can sustain for 4 hrs without tripping at 23°C.

## ■ Trip current ( $I_{trip}$ )

Minimum current device at which device will trip at 23°C.

## ■ Maximum voltage ( $V_{max}$ )

Maximum voltage device can withstand without damage at  $I_{max}$ .

## ■ Maximum current ( $I_{max}$ )

Maximum current device can withstand without damage at  $V_{max}$ .

## ■ Power dissipation ( $P_d$ )

Power dissipated from device when in the tripped state.

## ■ $R_{1max}$

Maximum resistance at 23°C measured one hour after tripping.

## ■ Leakage current in the tripped state ( $I_{leak}$ )

When the PPTC device is latched in its high-resistance state, the amount of current allowed to pass through the device is a fraction of the fault current. The current can be calculated by using the following equation:

$$I = P_d / V_{ps}$$

$I$  = Leakage current of the device in the tripped state.

$P_d$  = Power dissipated by the PPTC device.

$V_{ps}$  = Voltage across the PPTC device.

## ■ $R_i \max$

Maximum device resistance in initial state at 23°C.

## ■ $R_i \min$

Minimum device resistance in initial state at 23°C.

## ■ Time to trip ( $T_{tT}$ )

The time needed from the onset of a fault current to trip a PPTC device. For any particular type of PPTC device, trip time depends upon the size of the fault current and/or the higher the temperature, the shorter the trip temp.

# PPTC Thermistor Application Note



## ■ General electronic applications

### ● Motors, fans and blowers

If the motors are under overload, the extremely fine wire will be damaged by overheating. Install of PPTC in motors and blowers to prevent from overheating if overloaded.

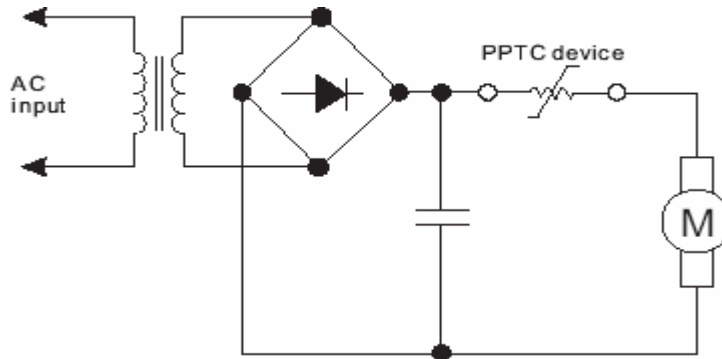

### ● Industrial process controls

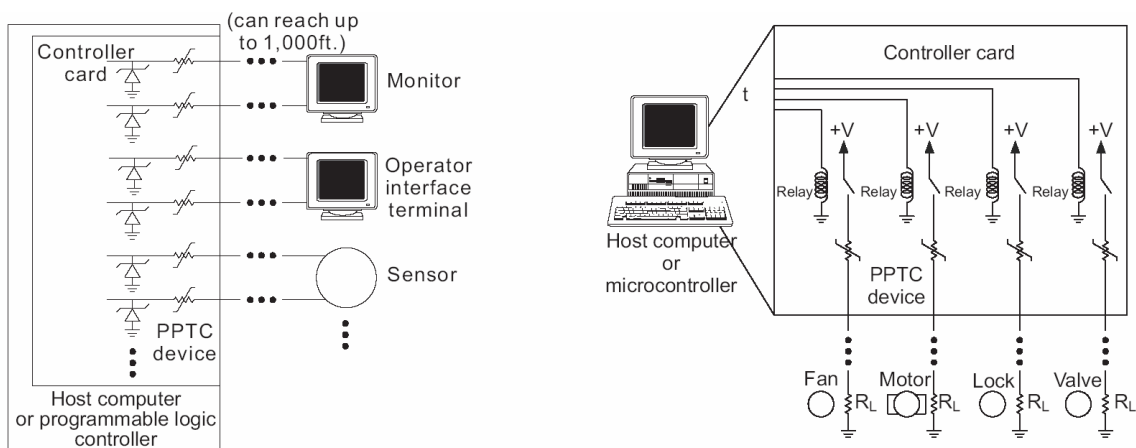

## ■ Computer applications

### ● Keyboard/ mouse

The operating current of keyboard/ mouse are usually from 200 to 500 mA, but in a short circuit the current will increase many times. Using PPTC in series between the connector and host power supply will limit the current cut the keyboard/ mouse port to the specified maximum.

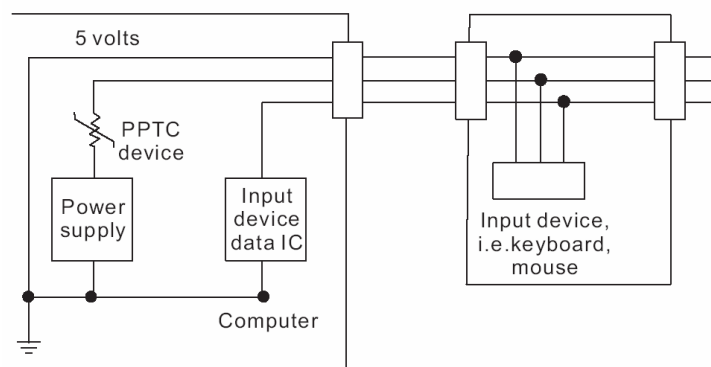

# PPTC Thermistor Application Note



## ● Hard disk driver

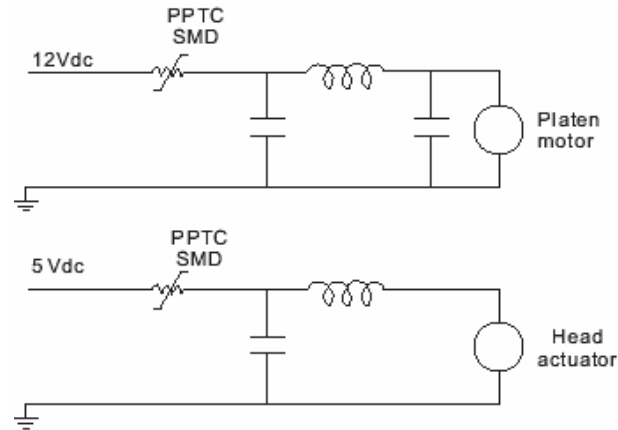

## ■ Battery applications

### ● Rechargeable battery packs

Using strap type PPTC in series within battery pack will avoid the followed faults occurring.

- Shorting of the positive and negative terminals.
- A runaway charging condition in which the charger during charging, fails to stop supplying current to the package when it is fully charged.
- Using the wrong charger or the pack is reverse charged.

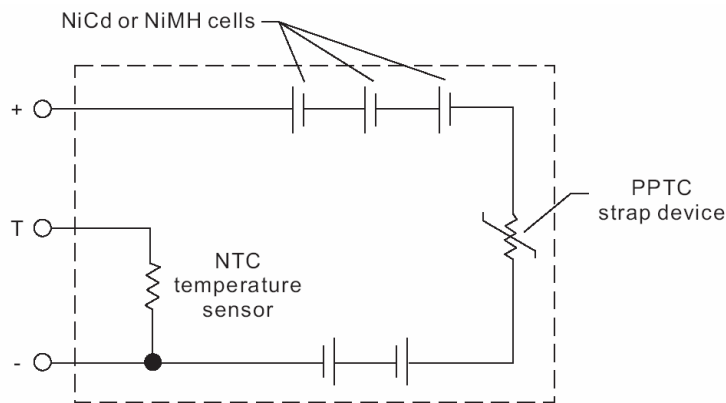

### ● Prismatic lithium battery

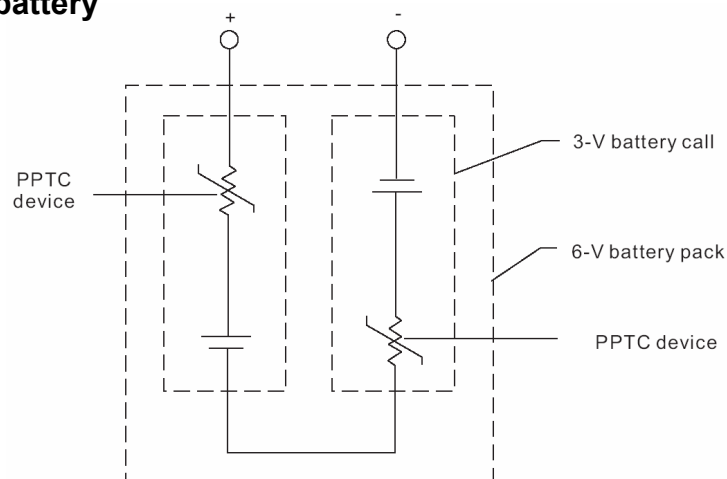

# PPTC Thermistor Application Note



## ■ Automotive applications

### ● Automotive harness

The conventional solution in wire harnesses is that groups similar circuits together and protects them with a single fuse. In order to limit risk of fire, the wire high current carrying capability, and the oversized wire is commonly used. If anyone circuit under the same fuse short, the other circuits will all stop. PPTC devices can be installed to each circuit, which allows the optimum wire to be selected. And the other hand, the circuits don't have to be through the central fuse box, thus reducing the length of wire required.

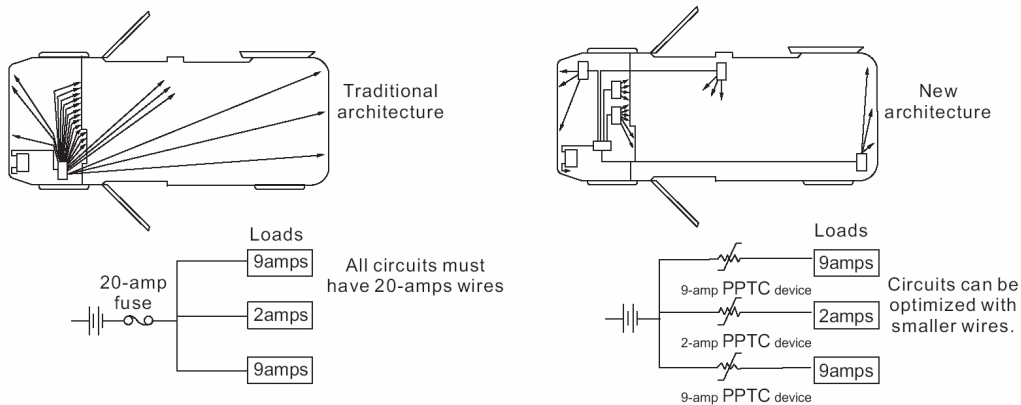

### ● Automotive electronics

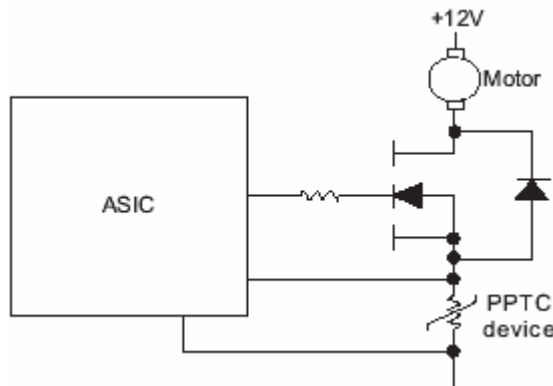

## ■ Telecom applications

### ● Network equipment

The telecom networks are potentially exposed to AC power crosses, thunder hazard, induced over current in the networks. The PPTC devices which are in series with line feed resistor and in paralleled with MOV will protect against these faults and prevent network equipments from damage.

