



Quartz Crystal Oscillators



www.sigtra.com.tr



No.	SGS Report No.	Report Date



Attention

Products of Chequers Electronic (China) Limited (hereafter “Chequers”) shall not be used within any critical systems, which require especially high reliability. Critical systems mean, if such systems fail, one can reasonably expect that failure in such systems will result in damage to a third party’s life, body or property. In case products of Chequers must be used in critical systems, please consult with our sales representatives before using products from Chequers.



When using CQ products...

1. Do not apply voltage exceeding the rated voltage of components
2. Be certain not to operate outside the recommended operating temperature range of components
3. Be careful of soldering temperature and duration of components when soldering
4. Do not place soldering iron on the body of components
5. Be careful not to subject the terminals or leads of components to excessive force
6. Pay attention to the type of flux cleaning solvents that may damage components
7. Please contact our sales representatives or engineers before using the products specified in this specification sheet for the following equipment, which require high reliability, and if such equipment fails, which might damage to a third party’s life, body or property.
 - (i) Aerospace equipment
 - (ii) Medical equipment
 - (iii) Power plant equipment
 - (iv) Transportation equipment
 - (v) Traffic control equipment
 - (vi) Disaster control / prevention equipment
 - (vii) Undersea navigational equipment
 - (viii) Data-processing equipment
 - (ix) Or equipment that requires similar complexity and / or reliability of above equipment
8. Product specifications in this specification sheet are as of the date that is printed on, and they are for reference only. They are subject to change or discontinue without prior notice. Please check with our sales representative or engineers for details.
9. When using our products, please do not exceed the requirements and conditions specified in this specification sheet.
10. Should there be any doubt when using our products, please consult our sales representative or engineers before using our products.



Quartz Crystal Oscillator (7.0 x 5.0 x 1.4mm, HCMOS/TTL)

Dimension and Recommended Soldering Pattern

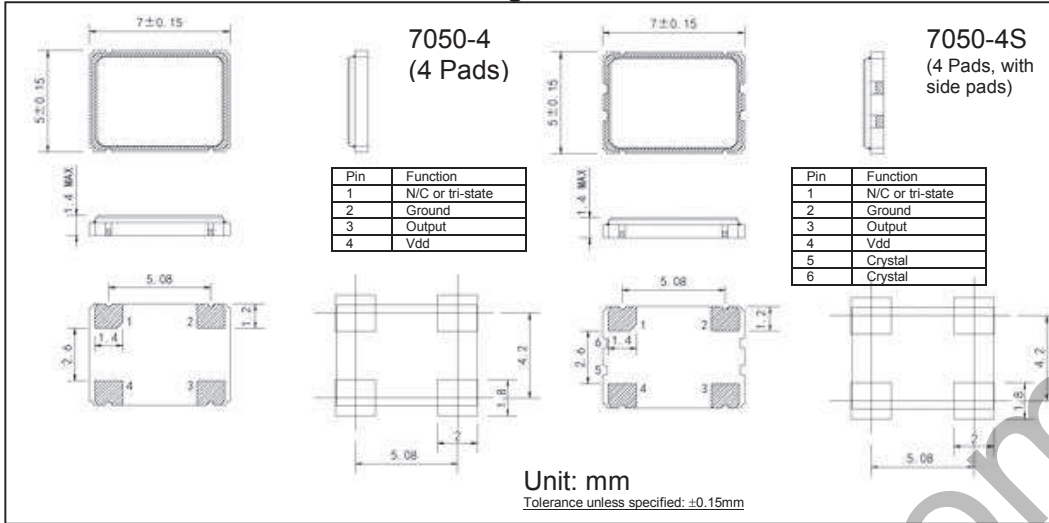

RoHS Compliant
Directive 2002/95/EC

REACH Compliant
(15 SVHCs)
Regulation (EC) No.
1907/2006

TS16949:2002
Certified

Electrical Specifications

Holder type	7050-4 (7.0 x 5.0 x 1.4mm, surface-mounted, 4 pads) 7050-4S (7.0 x 5.0 x 1.4mm, surface-mounted, 4 pads with side pads)
Frequency range	1.0000MHz to 150.000MHz
Frequency stability	±25ppm to ±50ppm
Supply voltage	1.8V, 2.5V, 2.85V, 3.3V or 5.0V (tolerance: ±10%)
Operating temperature range	-10°C ~ +60°C to -40°C ~ +85°C
Storage temperature range	-40°C ~ +85°C to -55°C ~ +125°C
Symmetry (duty cycle)	40 / 60 standard
Output load	10 TTL or 15pF HCMOS
Current consumption (15pF only, 5.0V)	- 1.0000 to 36.000MHz: 25mA max. - 36.000 to 70.000MHz: 60mA max. - 70.000 to 150.00MHz: 80mA max.
Current consumption (15pF only, 1.8V, 2.5V, 2.85V, 3.3V)	- 1.0000 to 36.000MHz: 20mA max. - 36.000 to 70.000MHz: 40mA max. - 70.000 to 150.00MHz: 60mA max.
Rise / fall time	10ns max.

- The above information is for reference only. For other frequencies or specifications, please consult with our sales representatives for details.

Test Circuit

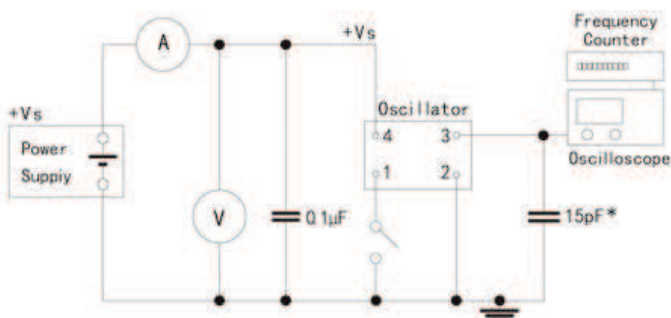



Quartz Crystal Oscillator (7.0 x 5.0 x 1.7mm, LVDS)

Dimension and Recommended Soldering Pattern

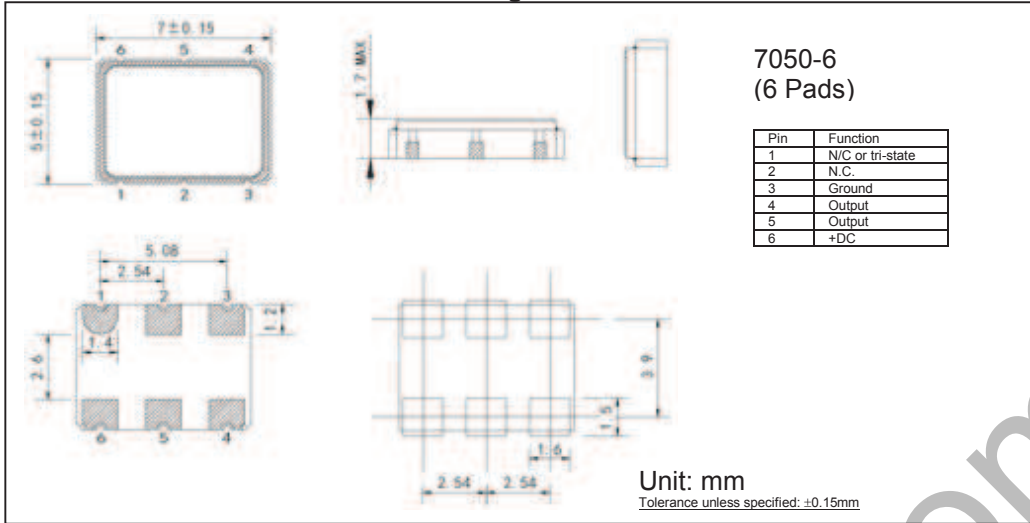

RoHS Compliant
Directive 2002/95/EC

REACH Compliant
(15 SVHCs)
Regulation (EC) No.
1907/2006

TS16949:2002
Certified

Electrical Specifications

Holder type	7050-6 (7.0 x 5.0 x 1.7mm, surface-mounted, 6 pads)
Frequency range	1.0000MHz to 220.000MHz
Frequency stability	±25ppm to ±50ppm
Supply voltage	2.5V or 3.3V (±10%)
Operating temperature range	-10°C ~ +60°C to -40°C ~ +85°C
Storage temperature range	-40°C ~ +85°C to -55°C ~ +125°C
Symmetry (duty cycle)	40 / 60 standard
Load	100Ω
Current consumption	
- 2.5V	55mA typical (88mA max.)
- 3.3V	60mA typical (90mA max.)
Phase noise	-130dBc/Hz@1KHz (155.52MHz, 3.3V)
Rms jitter (12KHz to 20MHz)	0.17Ps(156.25MHz, 3.3V)
Typical frequencies	61.44MHz, 122.88MHz, 155.52MHz, 156.25MHz

- The above information is for reference only. For other frequencies or specifications, please consult with our sales representatives for details.

Test Circuit

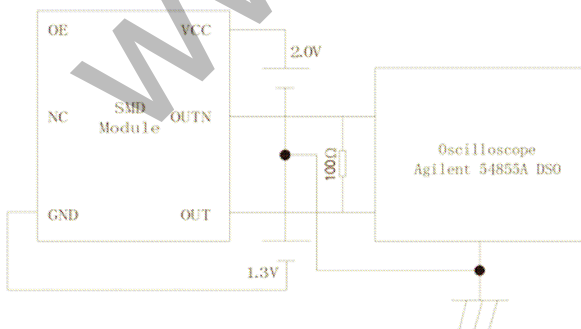



Quartz Crystal Oscillator (7.0 x 5.0 x 1.7mm, PECL)

● Dimension and Recommended Soldering Pattern

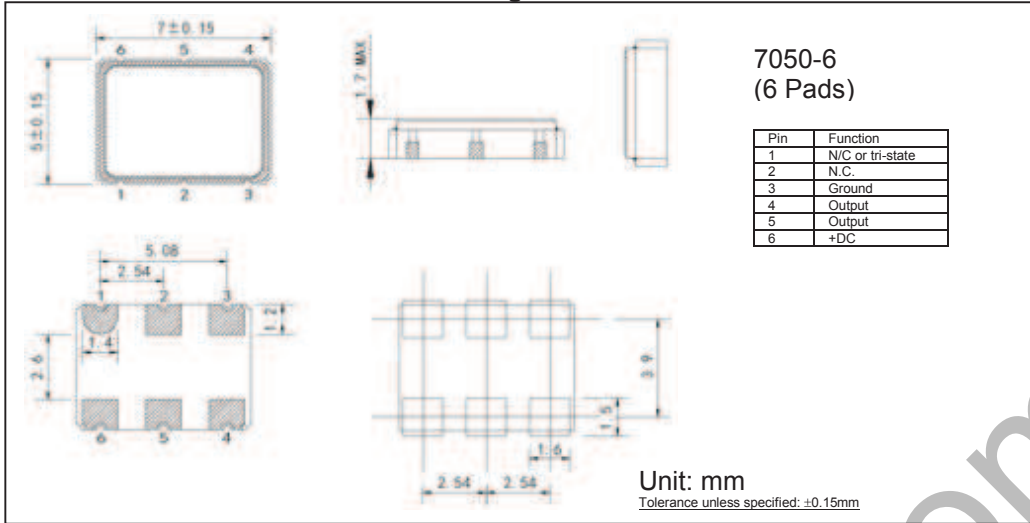

RoHS Compliant
Directive 2002/95/EC

REACH Compliant
(15 SVHCs)
Regulation (EC) No.
1907/2006

TS16949:2002
Certified

● Electrical Specifications

Holder type	7050-6 (7.0 x 5.0 x 1.7mm, surface-mounted, 6 pads)
Frequency range	1.0000MHz to 220.000MHz
Frequency stability	$\pm 25\text{ppm}$ to $\pm 50\text{ppm}$
Supply voltage	2.5V or 3.3V ($\pm 10\%$)
Operating temperature range	$-10^{\circ}\text{C} \sim +60^{\circ}\text{C}$ to $-40^{\circ}\text{C} \sim +85^{\circ}\text{C}$
Storage temperature range	$-40^{\circ}\text{C} \sim +85^{\circ}\text{C}$ to $-55^{\circ}\text{C} \sim +125^{\circ}\text{C}$
Symmetry (duty cycle)	40 / 60 standard
Load	50 Ω
Current consumption	
- 2.5V	55mA typical (88mA max.)
- 3.3V	60mA typical (90mA max.)
Phase noise	-130dBc/Hz@1KHz (155.52MHz, 3.3V)
Rms jitter (12KHz to 20MHz)	0.17Ps(156.25MHz, 3.3V)
Typical frequencies	61.44MHz, 122.88MHz, 155.52MHz, 156.25MHz

- The above information is for reference only. For other frequencies or specifications, please consult with our sales representatives for details.

● Test Circuit

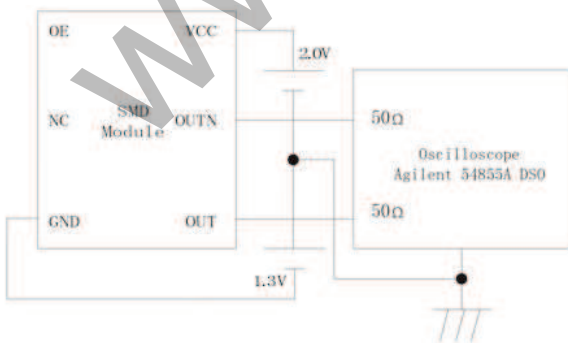



Quartz Crystal Oscillator (5.0 x 3.2 x 1.3mm, HCMOS/TTL)

● Dimension and Recommended Soldering Pattern

5032-4
(4 Pads)

Pin	Function
1	N/C or tri-state
2	Ground
3	Output
4	Vdd

Unit: mm
Tolerance unless specified: $\pm 0.15\text{mm}$

RoHS Compliant
Directive 2002/95/EC

REACH Compliant
(15 SVHCs)
Regulation (EC) No.
1907/2006

TS16949:2002
Certified

● Electrical Specifications

Holder type	5032-4 (5.0 x 3.2 x 1.3mm, surface-mounted, 4 pads)
Frequency range	1.0000MHz to 150.000MHz
Frequency stability	$\pm 25\text{ppm}$ to $\pm 50\text{ppm}$
Supply voltage	1.8V, 2.5V, 2.85V, 3.3V or 5.0V (tolerance: $\pm 10\%$)
Operating temperature range	$-10^{\circ}\text{C} \sim +60^{\circ}\text{C}$ to $-40^{\circ}\text{C} \sim +85^{\circ}\text{C}$
Storage temperature range	$-40^{\circ}\text{C} \sim +85^{\circ}\text{C}$ to $-55^{\circ}\text{C} \sim +125^{\circ}\text{C}$
Symmetry (duty cycle)	40 / 60 standard
Output load	10 TTL or 15pF HCMOS
Current consumption (15pF only, 5.0V)	
- 1.0000 to 36.000MHz	25mA max.
- 36.000 to 70.000MHz	60mA max.
- 70.000 to 150.00MHz	80mA max.
Current consumption (15pF only, 1.8V, 2.5V, 2.85V, 3.3V)	
- 1.0000 to 36.000MHz	20mA max.
- 36.000 to 70.000MHz	40mA max.
- 70.000 to 150.00MHz	60mA max.
Rise / fall time	10ns max.

- The above information is for reference only. For other frequencies or specifications, please consult with our sales representatives for details.

● Test Circuit

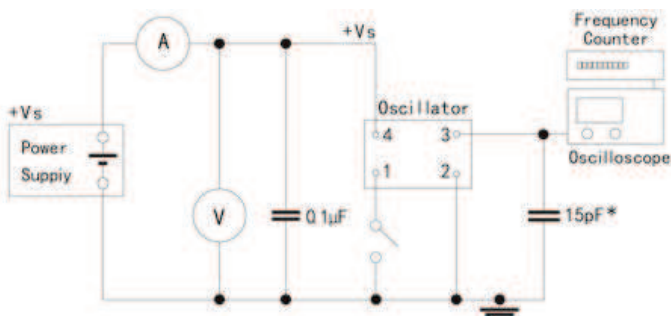



Quartz Crystal Oscillator (3.2 x 2.5 x 1.2mm, HCMOS/TTL)

● Dimension and Recommended Soldering Pattern

3225-4
(4 Pads)

Pin	Function
1	N/C or tri-state
2	Ground
3	Output
4	Vdd

Unit: mm
Tolerance unless specified: $\pm 0.15\text{mm}$

RoHS Compliant
Directive 2002/95/EC

REACH Compliant
(15 SVHCs)
Regulation (EC) No.
1907/2006

TS16949:2002
Certified

● Electrical Specifications

Holder type	3225-4 (3.2 x 2.5 x 1.2mm, surface-mounted, 4 pads)
Frequency range	1.0000MHz to 150.000MHz
Frequency stability	$\pm 25\text{ppm}$ to $\pm 50\text{ppm}$
Supply voltage	1.8V, 2.5V, 2.85V, 3.3V or 5.0V (tolerance: $\pm 10\%$)
Operating temperature range	$-10^{\circ}\text{C} \sim +60^{\circ}\text{C}$ to $-40^{\circ}\text{C} \sim +85^{\circ}\text{C}$
Storage temperature range	$-40^{\circ}\text{C} \sim +85^{\circ}\text{C}$ to $-55^{\circ}\text{C} \sim +125^{\circ}\text{C}$
Symmetry (duty cycle)	40 / 60 standard
Output load	10 TTL or 15pF HCMOS
Current consumption (15pF only, 5.0V) - 1.0000 to 150.000MHz	25mA max.
Current consumption (15pF only, 1.8V, 2.5V, 2.85V, 3.3V) - 1.0000 to 150.000MHz	20mA max.
Rise / fall time	10ns max.

- The above information is for reference only. For other frequencies or specifications, please consult with our sales representatives for details.

● Test Circuit

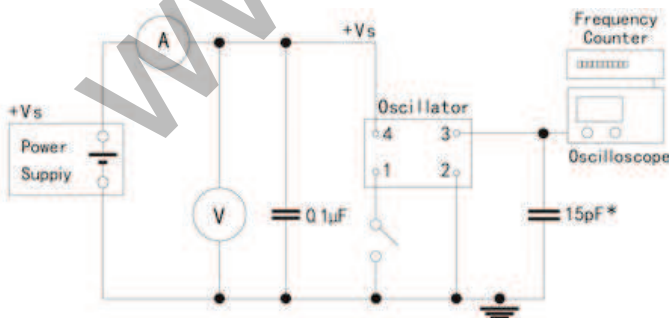



Quartz Crystal Oscillator (2.5 x 2.0 x 1.0mm, HCMOS/TTL)

● Dimension and Recommended Soldering Pattern

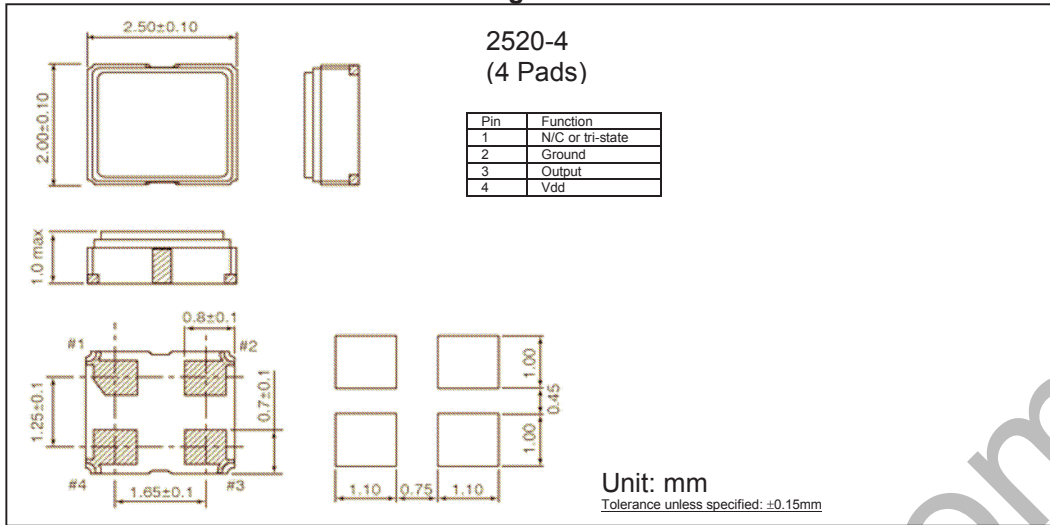

RoHS Compliant
Directive 2002/95/EC

REACH Compliant
(15 SVHCs)
Regulation (EC) No.
1907/2006

TS16949:2002
Certified

● Electrical Specifications

Holder type	2520-4 (2.5 x 2.0 x 1.0mm, surface-mounted, 4 pads)
Frequency range	1.0000MHz to 60.000MHz
Frequency stability	±25ppm to ±50ppm
Supply voltage	1.8V, 2.5V, 2.85V, 3.3V or 5.0V (tolerance: ±10%)
Operating temperature range	-10°C ~ +60°C to -40°C ~ +85°C
Storage temperature range	-40°C ~ +85°C to -55°C ~ +125°C
Symmetry (duty cycle)	40 / 60 standard
Output load	10 TTL or 15pF HCMOS
Current consumption (15pF only, 5.0V) - 1.0000 to 60.000MHz	15mA max.
Current consumption (15pF only, 1.8V, 2.5V, 2.85V, 3.3V) - 1.0000 to 60.000MHz	10mA max.
Rise / fall time	10ns max.

- The above information is for reference only. For other frequencies or specifications, please consult with our sales representatives for details.

● Test Circuit

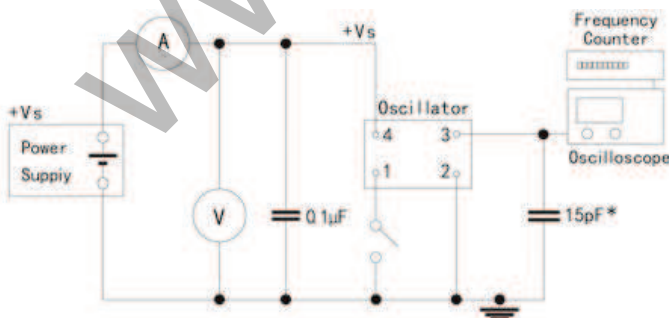



VCXO (7.0 x 5.0 x 1.8mm)

● Dimension and Recommended Soldering Pattern

**7050-6
(6 Pads)**

Pin	Function
1	Voltage control
2	N/C or tri-state
3	Ground
4	Output 1
5	Output 2
6	Vdd

Unit: mm
Tolerance unless specified: $\pm 0.15\text{mm}$

RoHS Compliant
Directive 2002/95/EC

REACH Compliant
(15 SVHCs)
Regulation (EC) No.
1907/2006

TS16949:2002
Certified

● Electrical Specifications

Holder type	7050-6 (7.0 x 5.0 x 1.8mm, surface-mounted, 6 pads)	
Frequency range	1.0000MHz to 80.000MHz	60.000MHz to 250.000MHz
Frequency stability	$\pm 25\text{ppm}$ to $\pm 50\text{ppm}$	
Input voltage	5.0V or 3.3V ($\pm 10\%$)	3.3V $\pm 10\%$
Control voltage	1.65V $\pm 1.5\text{V}$ or 2.5V $\pm 2.25\text{V}$	1.65V $\pm 1.5\text{V}$
Input current	20mA max.	35mA max.
Operating temperature range	$-10^\circ\text{C} \sim +60^\circ\text{C}$ to $-40^\circ\text{C} \sim +85^\circ\text{C}$	
Storage temperature range	$-40^\circ\text{C} \sim +85^\circ\text{C}$ to $-55^\circ\text{C} \sim +125^\circ\text{C}$	
Rise / fall time	6.0ns max.	
Symmetry (duty cycle)	40 / 60 standard	
Linearity	10% max.	
Pullability	$\pm 50\text{ppm}$ to $\pm 100\text{ppm}$	
Phase noise	-140dBc/Hz@1KHz	-120dBc/Hz@1KHz
Rms jitter (12KHz to 20MHz)	1.0Ps max.	2.5Ps typical
Typical frequencies	2.048MHz, 16.384MHz, 32.768MHz, 61.44MHz, 70.656MHz, 77.76MHz	125MHz, 156.25MHz, 156.52MHz, 200MHz

- The above information is for reference only. For other frequencies or specifications, please consult with our sales representatives for details.

● Test Circuit

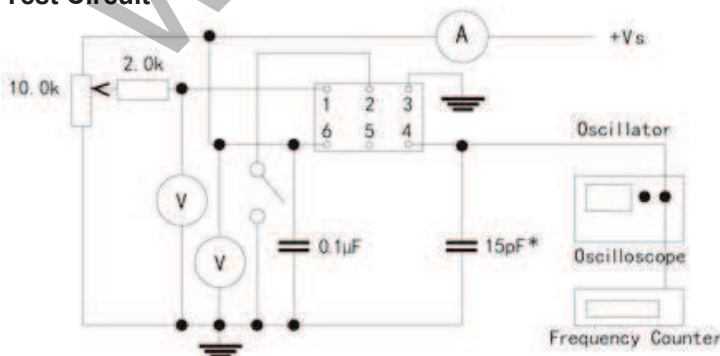



VCXO (7.0 x 5.0 x 1.8mm, LVDS)

● Dimension and Recommended Soldering Pattern

**7050-6
(6 Pads)**

Pin	Function
1	Voltage control
2	N/C or tri-state
3	Ground
4	Output 1
5	Output 2
6	Vdd

Unit: mm
Tolerance unless specified: $\pm 0.15\text{mm}$

RoHS Compliant
Directive 2002/95/EC

REACH Compliant
(15 SVHCs)
Regulation (EC) No.
1907/2006

TS16949:2002
Certified

● Electrical Specifications

Holder type	7050-6 (7.0 x 5.0 x 1.8mm, surface-mounted, 6 pads)	
Frequency range	1.0000MHz to 80.000MHz	60.0000MHz to 250.000MHz
Frequency stability	$\pm 25\text{ppm}$ to $\pm 50\text{ppm}$	
Input voltage	3.3V $\pm 10\%$	
Control voltage	1.65V $\pm 1.5\text{V}$ or 2.5V $\pm 2.25\text{V}$	
Input current	40mA max.	70mA max.
Operating temperature range	-10°C ~ +60°C to -40°C ~ +85°C	
Storage temperature range	-40°C ~ +85°C to -55°C ~ +125°C	
Rise / fall time	1.5ns max.	
Symmetry (duty cycle)	40 / 60 standard	
Linearity	10% max.	
Pullability	$\pm 50\text{ppm}$ to $\pm 100\text{ppm}$	
Phase noise	-130dBc/Hz@1KHz	-110dBc/Hz@1KHz
Rms jitter (12KHz to 20MHz)	0.25Ps typical	
Typical frequencies	61.44MHz, 77.56MHz	120.88MHz, 156.25MHz, 156.52MHz, 200MHz

- The above information is for reference only. For other frequencies or specifications, please consult with our sales representatives for details.

● Test Circuit

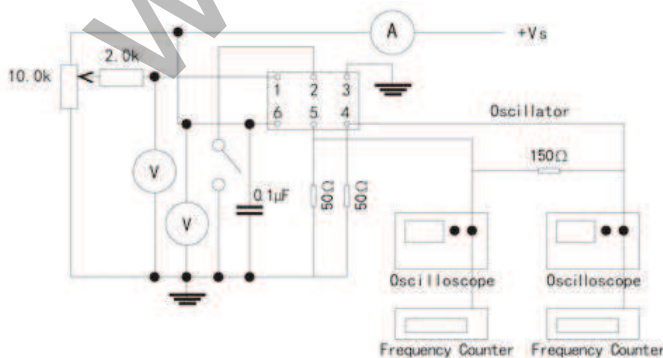



VCXO (7.0 x 5.0 x 1.8mm, PECL)

● Dimension and Recommended Soldering Pattern

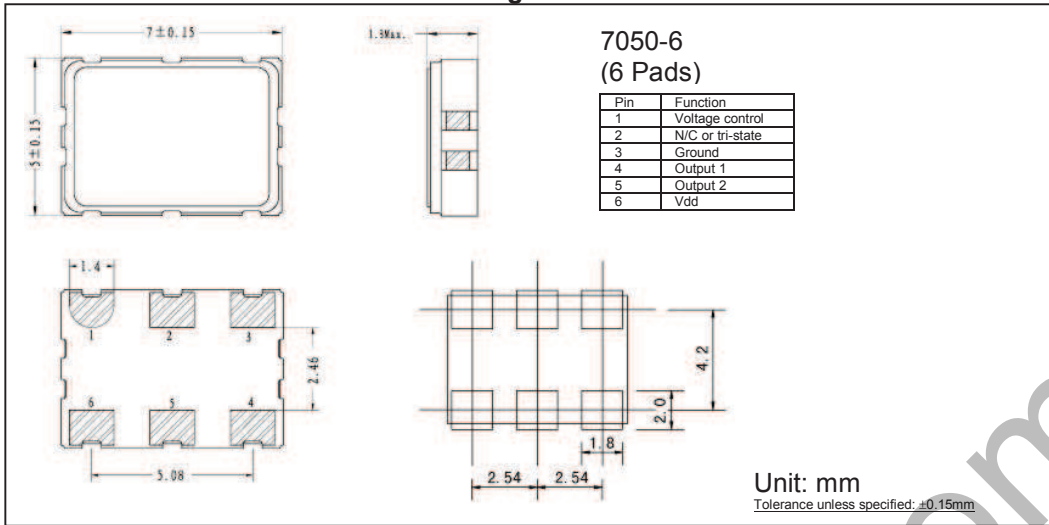

RoHS Compliant
Directive 2002/95/EC

REACH Compliant
(15 SVHCs)
Regulation (EC) No.
1907/2006

TS16949:2002
Certified

● Electrical Specifications

Holder type	7050-6 (7.0 x 5.0 x 1.8mm, surface-mounted, 6 pads)	
Frequency range	1.0000MHz to 80.000MHz	60.0000MHz to 250.000MHz
Frequency stability	±25ppm to ±50ppm	
Input voltage	3.3V±10%	
Control voltage	1.65V±1.5V	
Input current	40mA max.	70mA max.
Operating temperature range	-10°C ~ +60°C to -40°C ~ +85°C	
Storage temperature range	-40°C ~ +85°C to -55°C ~ +125°C	
Rise / fall time	1.5ns max.	
Symmetry (duty cycle)	40 / 60 standard	
Linearity	10% max.	
Pullability	±50ppm to ±100ppm	
Phase noise	-130dBc/Hz@1KHz	-110dBc/Hz@1KHz
Rms jitter (12KHz to 20MHz)	0.25Ps typical	
Typical frequencies	61.44MHz, 77.56MHz	122.88MHz, 156.25MHz, 156.52MHz, 168.0407MHz, 200MHz

- The above information is for reference only. For other frequencies or specifications, please consult with our sales representatives for details.

● Test Circuit

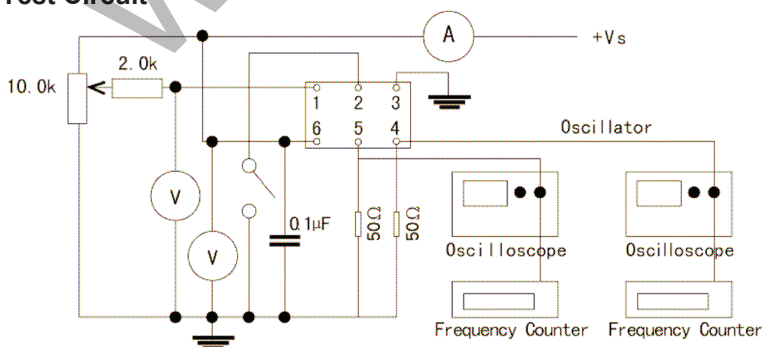



VCTCXO (3.2 x 2.5 x 1.2mm)

● Dimension and Recommended Soldering Pattern

3225-4
(4 Pads)

Pin	Function
1	Voltage control
2	N/C or tri-state
3	Ground
4	Output 1
5	Output 2
6	Vdd

Unit: mm
Tolerance unless specified: ±0.15mm

RoHS Compliant
Directive 2002/95/EC

REACH Compliant
(15 SVHCs)
Regulation (EC) No.
1907/2006

TS16949:2002
Certified

● Electrical Specifications

Holder type	3225-4 (3.2 x 2.5 x 1.2mm, surface-mounted, 4 pads)
Frequency range	8.0000MHz to 52.000MHz
Frequency tolerance	1.0ppm, 2.5ppm max.
Supply voltage	+1.68V to +3.3V
Load	(10KΩ//10pF) ±10%
Frequency stability	0.5ppm, 1.0ppm, 2.5ppm max.
- vs. supply voltage	±0.1ppm max. (VCC±5%)
- vs. load	±0.2ppm max. (10KΩ//10pF ±10% each)
Operating temperature range	-10°C ~ +60°C to -40°C ~ +85°C
Storage temperature range	-40°C ~ +85°C to -55°C ~ +125°C
Current consumption	2.0mA max.
Phase noise	
- 100KHz offset typical	-115dBc/Hz max.
- 1KHz offset typical	-125dBc/Hz max.
- 10KHz offset typical	-135dBc/Hz max.
Aging	±1ppm / year max.
Typical frequencies	13.000MHz, 19.200MHz, 19.680MHz, 26.000MHz

- The above information is for reference only. For other frequencies or specifications, please consult with our sales representatives for details.

● Test Circuit

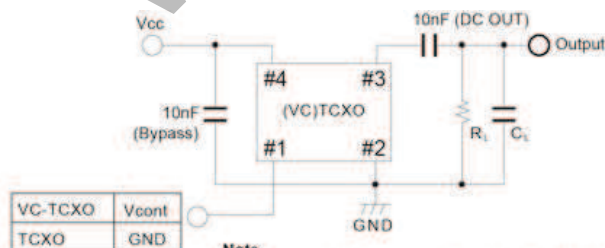

Note

Please connect a bypass capacitor closely to VCC Pad.
Load Capacitance(CL) includes probe and test board capacitance.



OCXO (36.3 x 27.1 x 12.7mm)

● **Dimension**

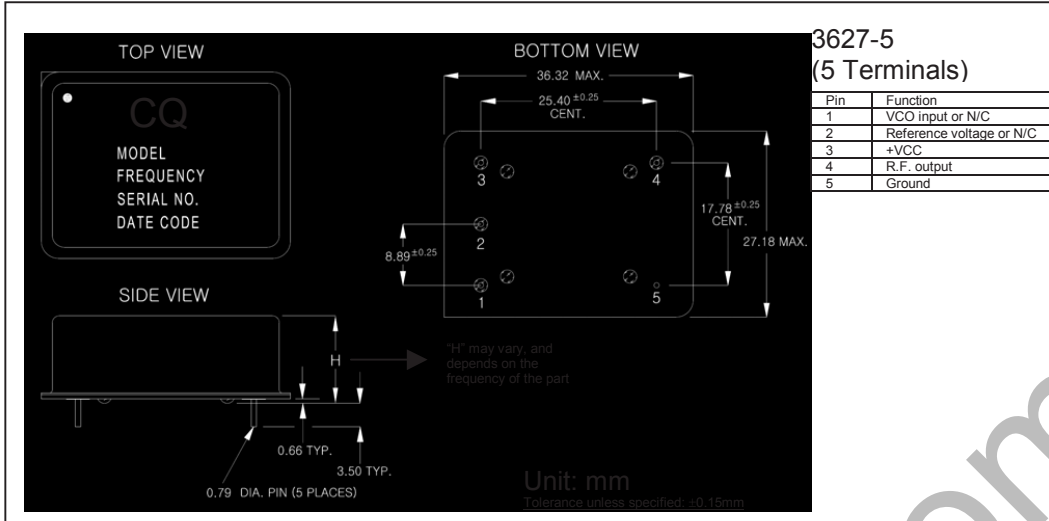

RoHS Compliant
Directive 2002/95/EC

REACH Compliant (15 SVHCs)
Regulation (EC) No. 1907/2006

TS16949:2002 Certified

● **Electrical Specifications**

Holder type	3627-5 (36.3 x 27.1 x 12.7mm, 5 terminals)			
Frequency range	5MHz to 50MHz			
Input voltage	3.3V, 5.0V, 12V			
Temperature range	-40°C ~ +85°C, -30°C ~ +75°C, -20°C ~ +70°C			
Temperature stability	±3ppb, ±5ppb, ±10ppb		±30ppb, ±50ppb, ±0.1ppm	
Waveform	LVTTTL, HCMOS, Sine wave			
Adjustment range	±0.5ppm to ±1.0ppm or no adjustment		±5ppm to ±10ppm or no adjustment	
Input voltage (for reference only)	3.3V±5%		5.0V±5%	
- Reference voltage	Not connected	2.8V	Not connected	4.0V
- VCO center voltage	1.65V	1.4V	2.5V	2.0V
- VCO input range	0 ~ 3.3V	0 ~ 2.8V	0 ~ 5.0V	0 ~ 4.0V

- The above information is for reference only. For other frequencies or specifications, please consult with our sales representatives for details.

● **Typical specification of a 10MHz OCXO**

Crystal type	SC-cut		AT-cut	
	Aging	Daily	< ±0.3ppb	Daily
	Yearly	< ±30ppb	Yearly	< ±0.3ppm
Warm-up time	< 3 minutes, to 5ppb of final frequency (30 minutes reading) @ +25°C		< 3 minutes, to 50ppb of final frequency (30 minutes reading) @ +25°C	
Warm-up power	< 3 Watts		< 3 Watts	
Steady state power	< 1.2 Watts @ +25°C		< 1.0 Watts @ +25°C	
Voltage stability	< ±0.5ppb @ Vcc±5%		< ±5ppb @ Vcc±5%	
Short-term stability	< 0.01ppb/s		< 0.1ppb/s	
Phase noise (typical values)	@ 1Hz	-98dBc/Hz	@ 1Hz	-85dBc/Hz
	@ 10Hz	-128dBc/Hz	@ 10Hz	-115dBc/Hz
	@ 100Hz	-150dBc/Hz	@ 100Hz	-143dBc/Hz
	@ 1KHz	-158dBc/Hz	@ 1KHz	-154dBc/Hz
	@ 10KHz	-164dBc/Hz	@ 10KHz	-164dBc/Hz
	@ 100KHz	-165dBc/Hz	@ 100KHz	-165dBc/Hz
Product height	12.7mm max.			



OCXO (25.7 x 25.7 x 12.7mm)

● Dimension

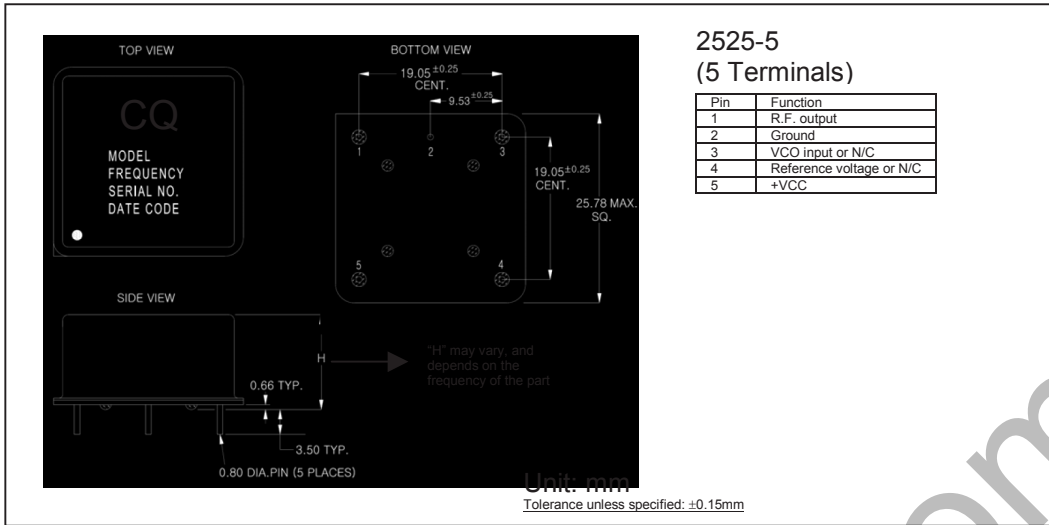

RoHS Compliant
Directive 2002/95/EC

REACH Compliant
(15 SVHCs)
Regulation (EC) No. 1907/2006

TS16949:2002 Certified

● Electrical Specifications

Holder type	2525-5 (25.7 x 25.7 x 12.7mm, 5 terminals)			
Frequency range	5MHz to 50MHz			
Input voltage	3.3V, 5.0V, 12V			
Temperature range	-40°C ~ +85°C, -30°C ~ +75°C, -20°C ~ +70°C			
Temperature stability	±3ppb, ±5ppb, ±10ppb	±30ppb, ±50ppb, ±0.1ppm		
Waveform	LVTTTL, HCMOS, Sine wave			
Adjustment range	±0.5ppm to ±1.0ppm or no adjustment	±5ppm to ±10ppm or no adjustment		
Input voltage (for reference only)	3.3V±5%	5.0V±5%		
- Reference voltage	Not connected	2.8V	Not connected	4.0V
- VCO center voltage	1.65V	1.4V	2.5V	2.0V
- VCO input range	0 ~ 3.3V	0 ~ 2.8V	0 ~ 5.0V	0 ~ 4.0V

- The above information is for reference only. For other frequencies or specifications, please consult with our sales representatives for details.

● Typical specification of a 12.8MHz OCXO

Crystal type	SC-cut		AT-cut	
	Aging	Daily	< ±0.3ppb	Daily
	Yearly	< ±30ppb	Yearly	< ±0.3ppm
Warm-up time	< 3 minutes, to 5ppb of final frequency (30 minutes reading) @ +25°C		< 3 minutes, to 50ppb of final frequency (30 minutes reading) @ +25°C	
Warm-up power	< 3 Watts		< 3 Watts	
Steady state power	< 1.2 Watts @ +25°C		< 1.0 Watts @ +25°C	
Voltage stability	< ±0.5ppb @ Vcc±5%		< ±5ppb @ Vcc±5%	
Short-term stability	< 0.01ppb/s		< 0.1ppb/s	
Phase noise (typical values)	@ 1Hz	-98dBc/Hz	@ 1Hz	-85dBc/Hz
	@ 10Hz	-128dBc/Hz	@ 10Hz	-115dBc/Hz
	@ 100Hz	-150dBc/Hz	@ 100Hz	-143dBc/Hz
	@ 1KHz	-158dBc/Hz	@ 1KHz	-154dBc/Hz
	@ 10KHz	-164dBc/Hz	@ 10KHz	-164dBc/Hz
	@ 100KHz	-165dBc/Hz	@ 100KHz	-165dBc/Hz
Product height	12.7mm max.			



OCXO (22.1 x 25.4 x 15.0mm)

● Dimension

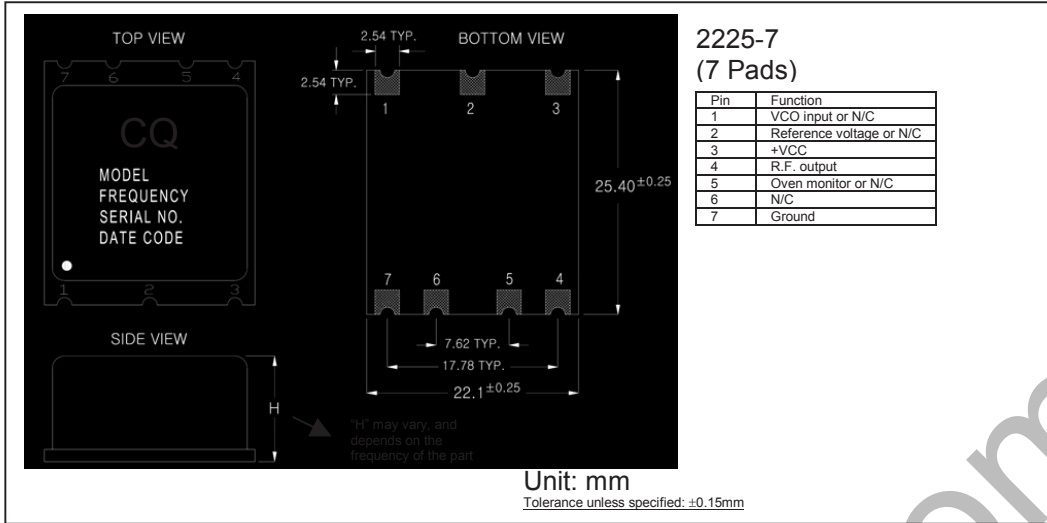

RoHS Compliant
Directive 2002/95/EC

REACH Compliant
(15 SVHCs)
Regulation (EC) No. 1907/2006

TS16949:2002
Certified

● Electrical Specifications

Holder type	2225-7 (22.1 x 25.4 x 15.0mm, 7 terminals)			
Frequency range	5MHz to 50MHz			
Input voltage	3.3V, 5.0V, 12V			
Temperature range	-40°C ~ +85°C, -30°C ~ +75°C, -20°C ~ +70°C			
Temperature stability	±3ppb, ±5ppb, ±10ppb		±30ppb, ±50ppb, ±0.1ppm	
Waveform	LVTTTL, HCMOS, Sine wave			
Adjustment range	±0.5ppm to ±1.0ppm or no adjustment		±5ppm to ±10ppm or no adjustment	
Input voltage (for reference only)	3.3V±5%		5.0V±5%	
- Reference voltage	Not connected	2.8V	Not connected	4.0V
- VCO center voltage	1.65V	1.4V	2.5V	2.0V
- VCO input range	0 ~ 3.3V	0 ~ 2.8V	0 ~ 5.0V	0 ~ 4.0V

- The above information is for reference only. For other frequencies or specifications, please consult with our sales representatives for details.

● Typical specification of a 10MHz OCXO

Crystal type	SC-cut		AT-cut	
	Aging	Daily	< ±0.3ppb	Daily
	Yearly	< ±30ppb	Yearly	< ±0.3ppm
Warm-up time	< 3 minutes, to 5ppb of final frequency (30 minutes reading) @ +25°C		< 3 minutes, to 50ppb of final frequency (30 minutes reading) @ +25°C	
Warm-up power	< 3 Watts		< 3 Watts	
Steady state power	< 1.2 Watts @ +25°C		< 1.0 Watts @ +25°C	
Voltage stability	< ±0.5ppb @ Vcc±5%		< ±5ppb @ Vcc±5%	
Short-term stability	< 0.01ppb/s		< 0.1ppb/s	
Phase noise (typical values)	@ 1Hz	-98dBc/Hz	@ 1Hz	-85dBc/Hz
	@ 10Hz	-128dBc/Hz	@ 10Hz	-115dBc/Hz
	@ 100Hz	-150dBc/Hz	@ 100Hz	-143dBc/Hz
	@ 1KHz	-158dBc/Hz	@ 1KHz	-154dBc/Hz
	@ 10KHz	-164dBc/Hz	@ 10KHz	-164dBc/Hz
	@ 100KHz	-165dBc/Hz	@ 100KHz	-165dBc/Hz
Product height	10.7mm max., 12.2mm max., 15.0mm max.			



OCXO (20.6 x 20.6 x 12.7mm)

● Dimension

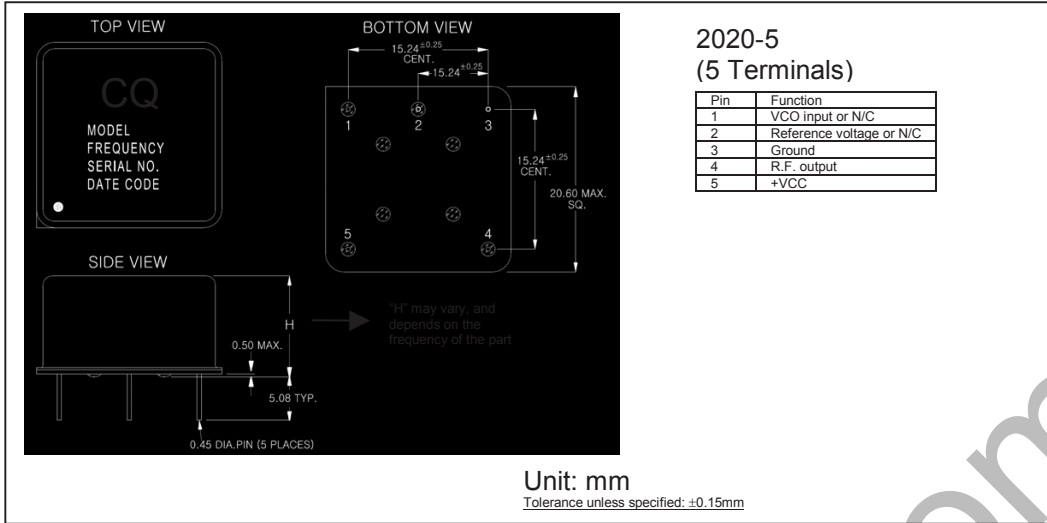

RoHS Compliant
Directive 2002/95/EC

REACH Compliant
(15 SVHCs)
Regulation (EC) No.
1907/2006

TS16949:2002
Certified

● Electrical Specifications

Holder type	2020-5 (20.6 x 20.6 x 12.7mm, 5 terminals)			
Frequency range	5MHz to 50MHz			
Input voltage	3.3V, 5.0V, 12V			
Temperature range	-40°C ~ +85°C, -30°C ~ +75°C, -20°C ~ +70°C			
Temperature stability	±3ppb, ±5ppb, ±10ppb		±30ppb, ±50ppb, ±0.1ppm	
Waveform	LVTTTL, HCMOS, Sine wave			
Adjustment range	±0.5ppm to ±1.0ppm or no adjustment		±5ppm to ±10ppm or no adjustment	
Input voltage (for reference only)	3.3V±5%		5.0V±5%	
- Reference voltage	Not connected	2.8V	Not connected	4.0V
- VCO center voltage	1.65V	1.4V	2.5V	2.0V
- VCO input range	0 ~ 3.3V	0 ~ 2.8V	0 ~ 5.0V	0 ~ 4.0V

- The above information is for reference only. For other frequencies or specifications, please consult with our sales representatives for details.

● Typical specification of a 10MHz OCXO

Crystal type	SC-cut		AT-cut	
	Aging	Daily	< ±0.3ppb	Daily
	Yearly	< ±30ppb	Yearly	< ±0.3ppm
Warm-up time	< 3 minutes, to 5ppb of final frequency (30 minutes reading) @ +25°C		< 3 minutes, to 50ppb of final frequency (30 minutes reading) @ +25°C	
Warm-up power	< 3 Watts		< 3 Watts	
Steady state power	< 1.2 Watts @ +25°C		< 1.0 Watts @ +25°C	
Voltage stability	< ±0.5ppb @ Vcc±5%		< ±5ppb @ Vcc±5%	
Short-term stability	< 0.01ppb/s		< 0.1ppb/s	
Phase noise (typical values)	@ 1Hz	-98dBc/Hz	@ 1Hz	-85dBc/Hz
	@ 10Hz	-128dBc/Hz	@ 10Hz	-115dBc/Hz
	@ 100Hz	-150dBc/Hz	@ 100Hz	-143dBc/Hz
	@ 1KHz	-158dBc/Hz	@ 1KHz	-154dBc/Hz
	@ 10KHz	-164dBc/Hz	@ 10KHz	-164dBc/Hz
	@ 100KHz	-165dBc/Hz	@ 100KHz	-165dBc/Hz
Product height	12.7mm max.			



OCXO (20.3 x 12.7 x 11.0mm)

● Dimension

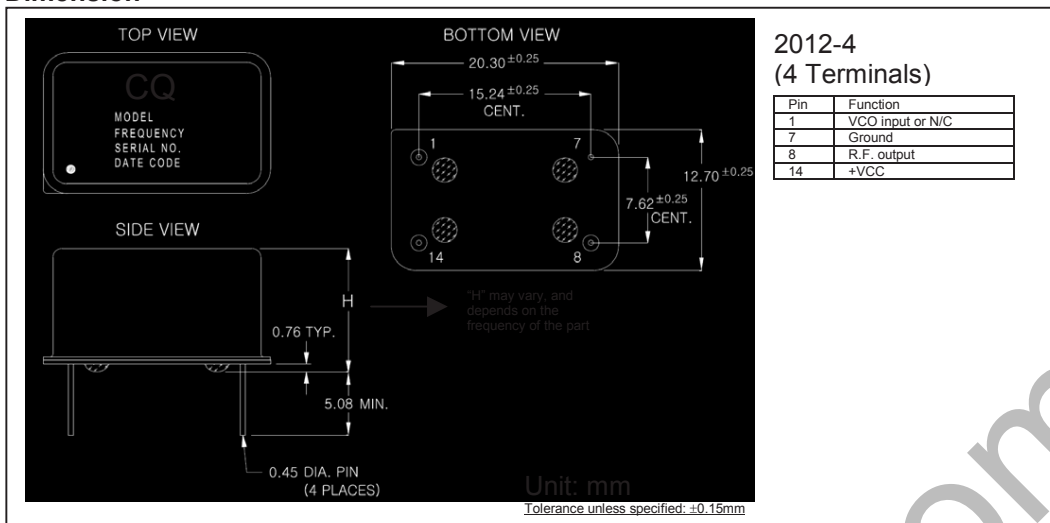

2012-4
(4 Terminals)

Pin	Function
1	VCO input or N/C
7	Ground
8	R.F. output
14	+VCC

RoHS Compliant
Directive 2002/95/EC

REACH Compliant
(15 SVHCs)
Regulation (EC) No.
1907/2006

TS16949:2002
Certified

● Electrical Specifications

Holder type	2012-4 (20.3 x 12.7 x 12.7mm, 4 terminals)	
Frequency range	5MHz to 50MHz	
Input voltage	3.3V, 5.0V, 12V	
Temperature range	-40°C ~ +85°C, -30°C ~ +75°C, -20°C ~ +70°C	
Temperature stability	±3ppb, ±5ppb, ±10ppb	±30ppb, ±50ppb, ±0.1ppm
Waveform	LVTTTL, HCMOS, Sine wave	
Adjustment range	±0.7ppm to ±2.0ppm or no adjustment	±5ppm to ±10ppm or no adjustment
Input voltage (for reference only)	3.3V±5%	5.0V±5%
- VCO center voltage	1.65V	2.5V
- VCO input range	0 ~ 3.3V	0 ~ 5.0V

- The above information is for reference only. For other frequencies or specifications, please consult with our sales representatives for details.

● Typical specification of a 25MHz OCXO

	SC-cut		AT-cut	
	Aging	Daily	< ±0.5ppb	Daily
	Yearly	< ±50ppb	Yearly	< ±0.3ppm
Warm-up time	< 3 minutes, to 5ppb of final frequency (30 minutes reading) @ +25°C		< 3 minutes, to 50ppb of final frequency (30 minutes reading) @ +25°C	
Warm-up power	< 2.5 Watts		< 2.5 Watts	
Steady state power	< 1.0 Watts @ +25°C		< 0.8 Watts @ +25°C	
Voltage stability	< ±0.5ppb @ Vcc±5%		< ±5ppb @ Vcc±5%	
Short-term stability	< 0.01ppb/s		< 0.1ppb/s	
Phase noise (typical values)	@ 1Hz	-92dBc/Hz	@ 1Hz	-80dBc/Hz
	@ 10Hz	-122dBc/Hz	@ 10Hz	-113dBc/Hz
	@ 100Hz	-145dBc/Hz	@ 100Hz	-143dBc/Hz
	@ 1KHz	-152dBc/Hz	@ 1KHz	-152dBc/Hz
	@ 10KHz	-160dBc/Hz	@ 10KHz	-160dBc/Hz
	@ 100KHz	-162dBc/Hz	@ 100KHz	-162dBc/Hz
Product height	11.0mm max.			